



MOBILE modular systems: Setting your concept in motion.

As easy as that.

Together we
are the force
behind the
markets of
tomorrow.

Innovation has a long tradition at Lenze

The use of electric drives opens up an increasing number of possibilities for forward-looking, green and economical vehicle concepts. Lenze Schmidhauser has been developing and producing energy-efficient and eco-friendly drive technology for around 25 years. The experience of our engineers and global network of experts, who are showing the way forward in the area of mobile applications, are poured into all the work they do – from the concept stage to providing advice and support in the prototype project, then every step of the way right through to production. This ensures innovative, reliable and economically efficient solutions for both electric and hybrid drives.

Get there faster with our solutions

Lenze mobile drives are products with a high degree of protection designed specifically for mobile applications. We offer power electronics up to large-scale production for auxiliary drives of hybrid and electric vehicles. These are used in generators, motors, battery and super-cap actuators, blowers, auxiliary steering pumps, air conditioning compressors, onboard converters and sockets for commercial vehicles.

Lenze mobile drive solutions show how easy electric mobility can be.

With our solutions from a single source, you profit from optimum harmonisation of the individual drives and the on-board power supply – everything with the same look and feel. Moreover, we provide you with the basis for perfectly coordinated energy management combined with comprehensive diagnostics. This makes it possible to reduce the effort and time spent on development, while lowering the costs of maintenance and service.

MOBILE: For electrical units in commercial vehicles.

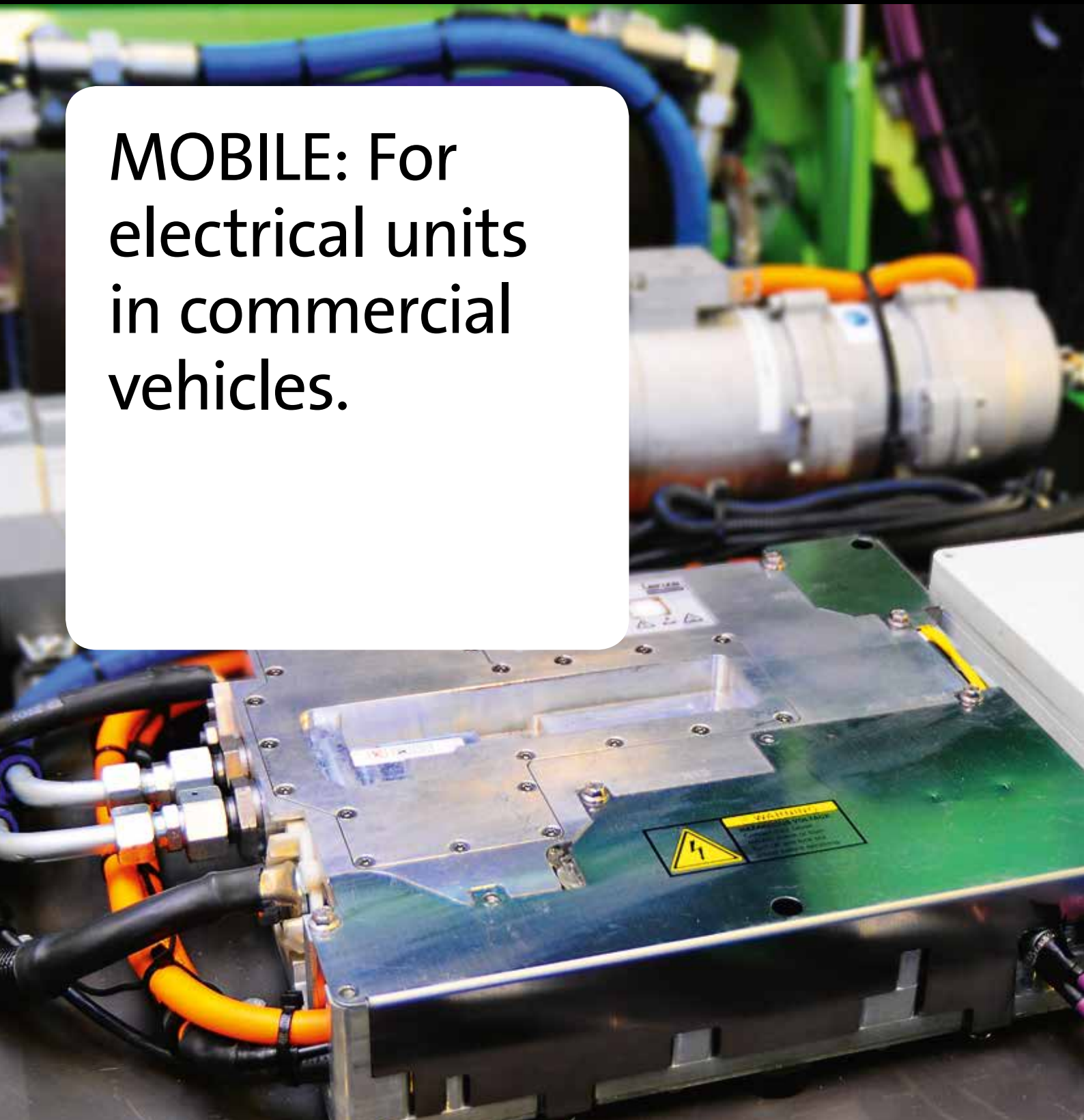

Based on its many years of experience, Lenze Schmidhauser has developed the compact MOBILE product platform with multi-inverters and DC/DC converters – for successful application in your vehicles.

When looking for the right products to suit your requirements, you have the option of choosing an electric modular drive system for applications in commercial vehicles.

You can find the right product type for your application with ease thanks to the catalogue-based approach of the MOBILE Advanced product line, which is optimised for individual applications. In addition, the scalability covers a wide power range with identical external dimensions.



MOBILE DCU
double inverter



MOBILE PSU
DC/DC converter



MOBILE DCU/PSU
inverter and DC/DC converter

The principle is quite simple: catalogue-based modular drive systems.

Vehicle manufacturers and parts suppliers can configure and create the best possible drive solution tailored to the respective task – quickly and without any irritating complications. Working with our customers, we always select the appropriate solution for your application. This is then easily integrated into the vehicle thanks to a consistent and uniform concept for the connections.

Your advantages

- Ready-to-use modular system
- Different versions available from series production
- Designed specifically for applications in commercial vehicles
- Basic housing concept for easy integration of devices of different power classes
- Makes your vehicle very energy-efficient
- Easy integration into your system
- Minimal development effort
- Low process complexity due to tried-and-tested series-produced components
- Short product launch times

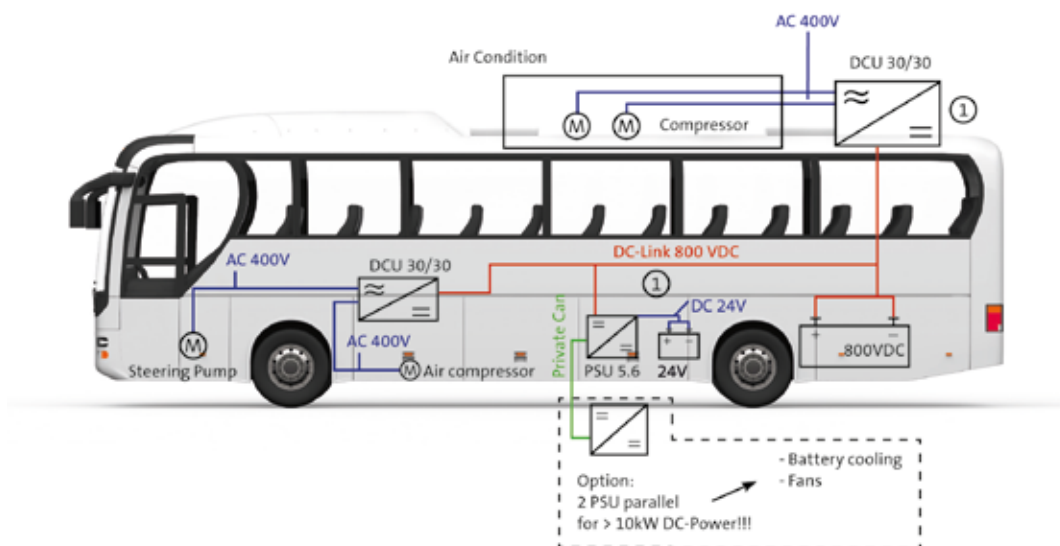

MOBILE Advanced Functions and features			
General		DCU	
Ambient temperature in area	- 40 °C ... +85 °C	Motor controller V/f or vector control	X
Cooling circuit	Water/glycol (50/50) 15l/min, +30 °C ... +65 °C	Continuous current DCU 7.5/15/30/60	*8 A/15 A/32 A/58 A
Connections	Plug screw terminals for DC/DC	Max. motor current	150 % for 60 s 180 % for 10 s
Shock & vibrations	5.9 G	Max. speed	20,000 rpm
Protection against environmental influences	IP6K9K	Max. output frequency	599 Hz
Certification	ECE R10	Motor feedback (resolver/thermal detector)	2
Interlock HW	X	Sensorless control for asynchronous motors	X
Readable error memory, cyclical error information	X	Sensorless control for synchronous motors	X
CANopen	X	Precharge of DC-link adjustable:	up to 300 V
CANbus J1939	X	PSU	
CANbus baud rate	1Mbit/s	Max. output current	adjustable
Digital outputs	4	Parallel mode	8 devices
Digital Inputs/FlexINs	4	Continuous current PSU 2.8/5.6	200 A
		Peak current PSU 2.8/5.6	200 A
		Precharge of DC-link adjustable: PSU 200 – 400 V PSU 400 – 800 V	up to 400 V up to 800 V
Available with SW release 6.0/HW revision 010 * continuous current for the 800 VDC variant			
<ul style="list-style-type: none"> • Certification: ECE R10 adaptation from revision 04 to revision 05 • Active Front End control power socket function • Parameter set changeover via terminal and CAN message • Actuation of up to 16 fixed speeds and torques via FlexINs, which are selected via the terminal control system • Precharging of DCU DC-link up to 800 V 			

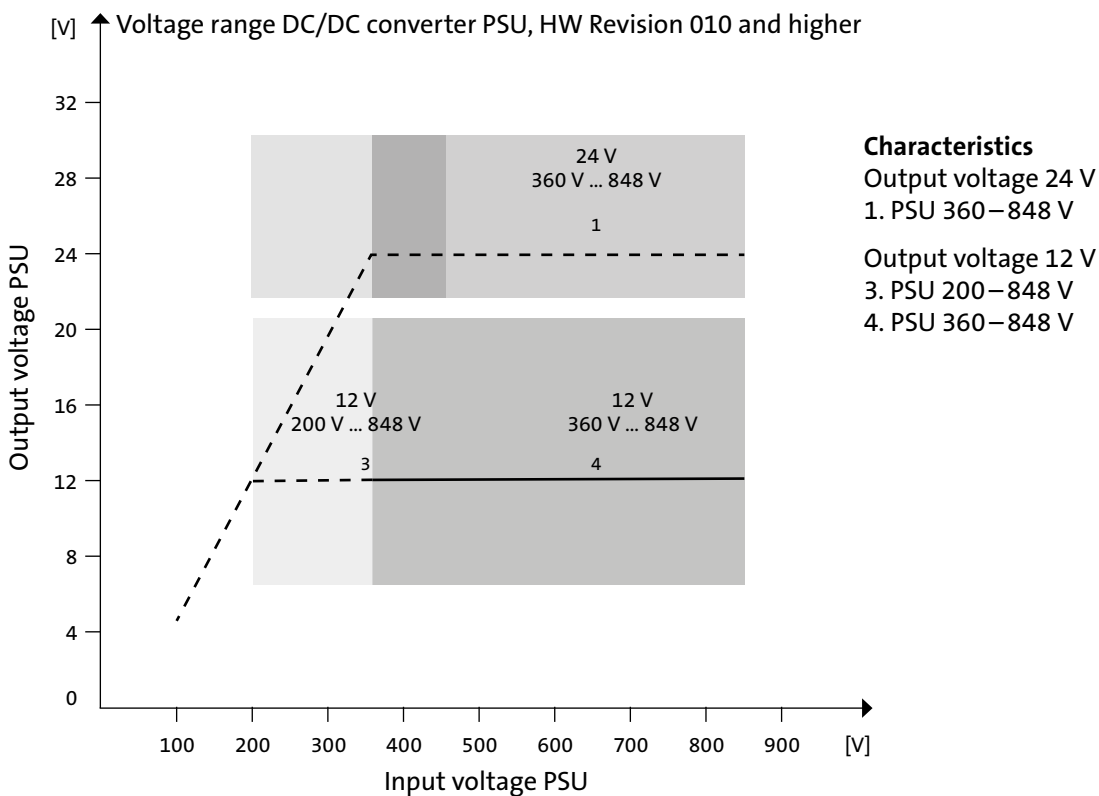

Always with an eye for the best solution.

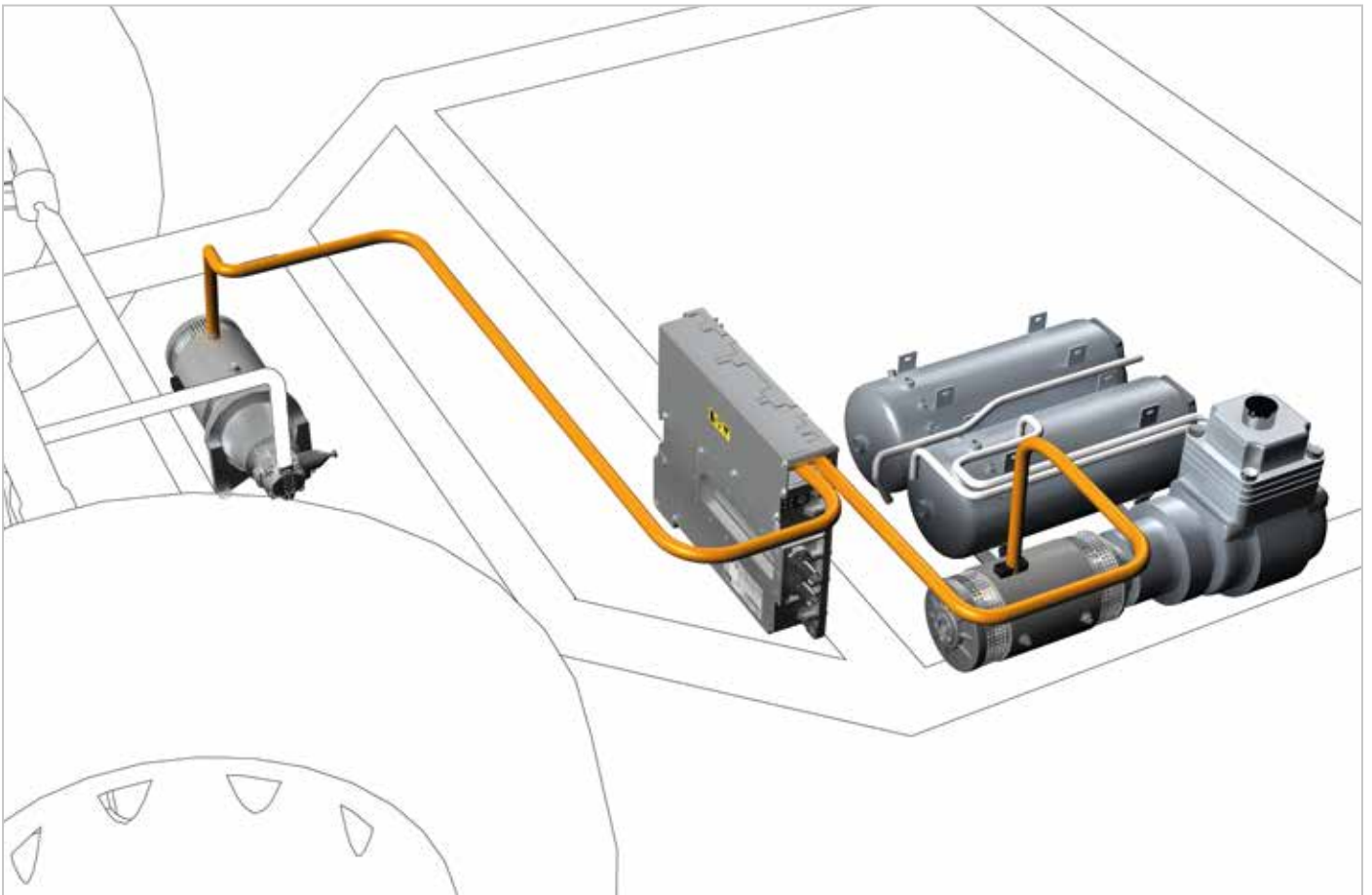

Optimum control of drives for steering-aid pumps and air compressors

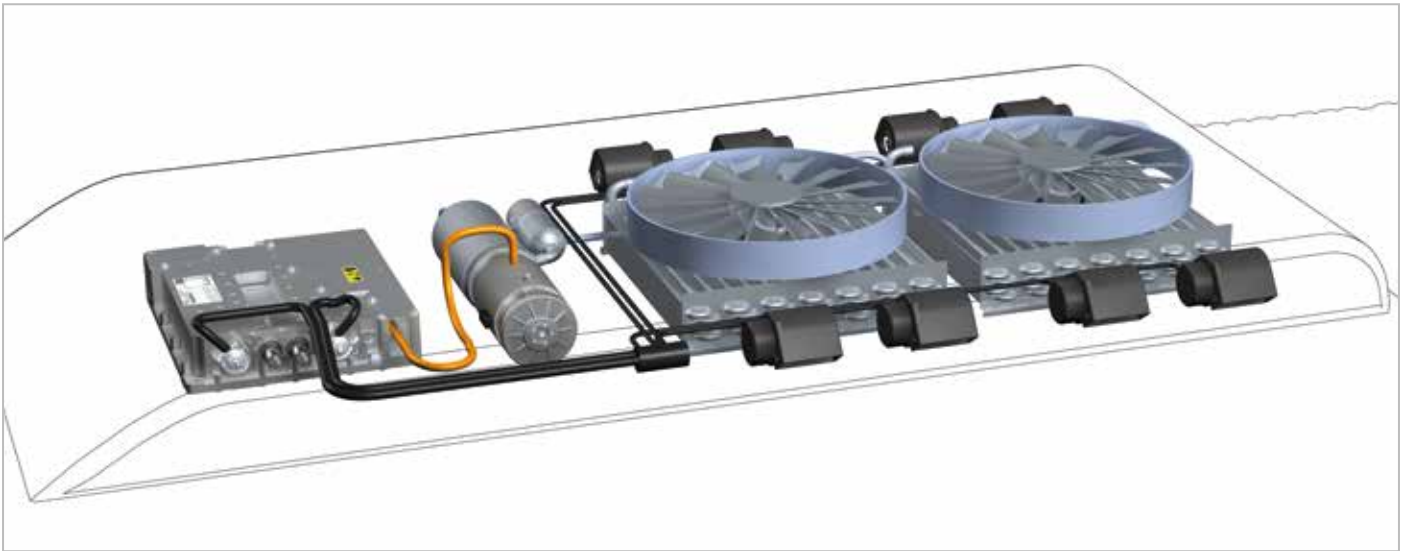

HVAC optionally with CAN communication or digital I/Os

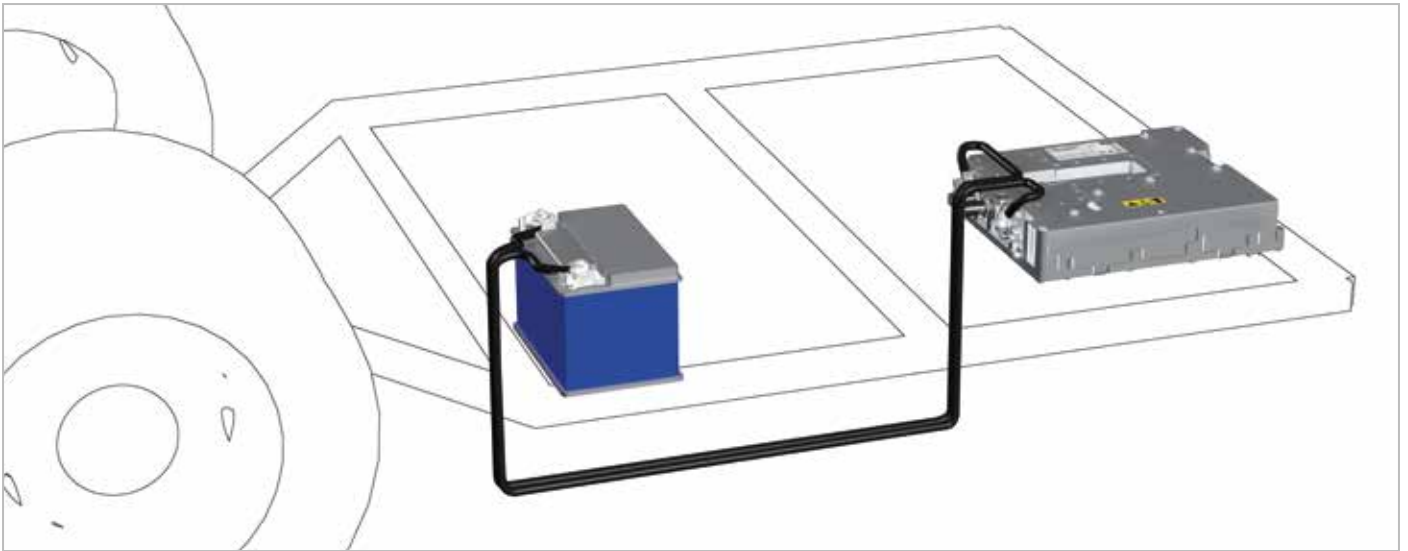

Provision of on-board supply system 12/24 V

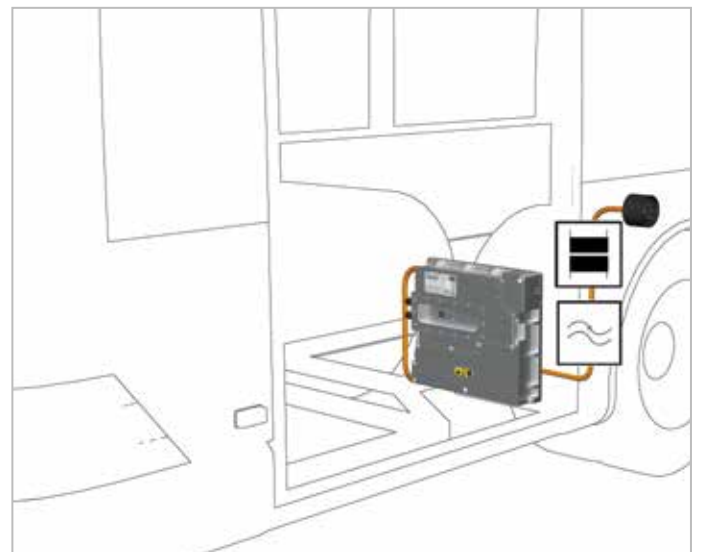
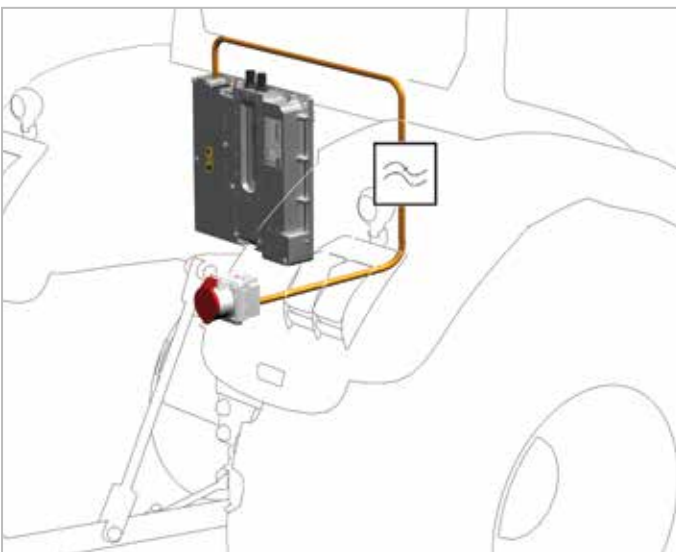

Active-front-end control for socket function and on-board charger.
The conformity to ECE R10 must be checked in the respective application.

Establishing efficient networks: communication.

Our offer for vehicle communication helps you to easily integrate the solution into the vehicle system via a standard communication bus.

Communication between vehicle and MOBILE devices

- Equipped with 2 independent CAN buses:
 - PrivateCAN parameterisation and communication between several interconnected devices – CANopen
 - PublicCAN communication with the primary vehicle control system – CANbus J1939

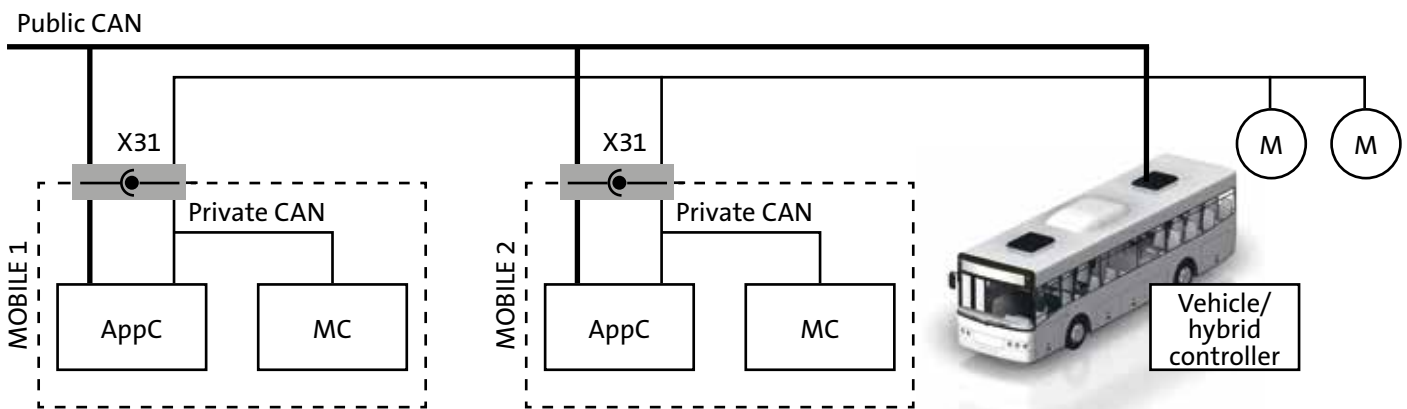

The MOBILE devices have two different micro controllers: Application Controller (AppC)

- AppC takes care of controlling and integrating the accessories into the vehicle and provides powerful diagnostics in accordance with UDS (Unified Diagnostic Services).

Motor Controller (MC)

- The two motors or the DC/DC converter are controlled by a powerful digital signal processor (DSP) which has been optimised for real-time control.

Complete access at any time: Parameterisation

Our tools for parameterisation and diagnostics provide you with full access to the devices at all times. The MOBILE tools make commissioning easier for you, optimise energy management, and facilitate

troubleshooting and debugging if there are any technical issues. Choose the right parameterisation tool to suit your needs – and make your engineering simple and efficient in the process.



MOBILE Starter

Tool for service technicians. Quick and easy commissioning and maintenance.

- Load parameters
- Extremely easy access to the device ID
- Device identification (request type designation + parameters)
- Communication test (CAN)



MOBILE Engineer

Your end-to-end engineering software. For parameterisation and configuration.

- Full access to parameterisation
- Fine tune MOBILE to the motor/load to be driven
- In-depth diagnostics
- Monitor device performance in real time
- Visualisation of the measurement, e.g. development of process values over time
- Individually adjustable screen masks

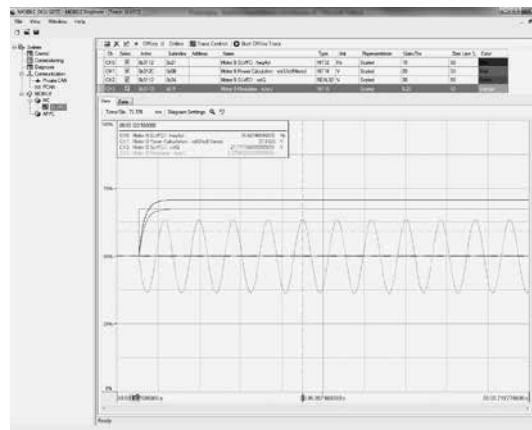
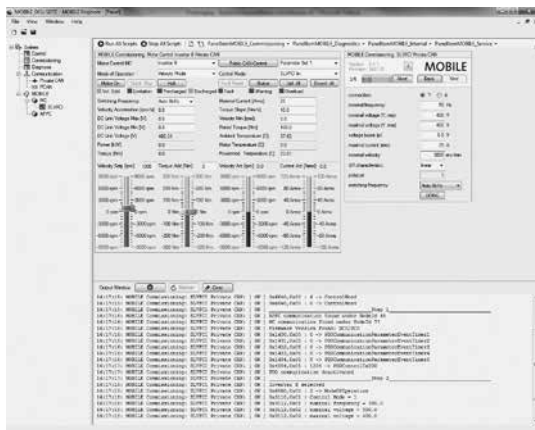

Your modular system at a glance – MOBILE Advanced

	Typ	Operating voltage	DCU/PSU peak power ¹	Secondary DC voltage	DCU/PSU output current nominal	DCU/PSU output current peak ²	Type number
Hardware revision 000							
DCU	60/60	200 ... 800 VDC	2 x 60 kW	-	2 x 58 A	2 x 104 A	EMDAG2603603U00000
	30/30	200 ... 800 VDC	2 x 30 kW	-	2 x 32 A	2 x 57 A	EMDAG2303303U00000
	30/15	200 ... 800 VDC	1 x 30 kW 1 x 15 kW	-	1 x 32 A 1 x 15 A	1 x 57 A 1 x 27 A	EMDAG2303153U00000
	15/7.5	200 ... 800 VDC	1 x 15 kW 1 x 7.5 kW	-	1 x 15 A 1 x 8 A	1 x 27 A 1 x 14 A	EMDAG2153752U00000
DCU PSU	60/5.6	400 ... 800 VDC	60 kW/5.6 kW	24 VDC	1 x 58 A/200 A	1 x 104 A/200 A	EMDAG4562603C00000
	60/2.8	400 ... 800 VDC	60 kW/2.8 kW	12 VDC	1 x 58 A/200 A	1 x 104 A/200 A	EMDAG4282603T00000
	30/5.6	400 ... 800 VDC	30 kW/5.6 kW	24 VDC	1 x 32 A/200 A	1 x 57 A/200 A	EMDAG4562303C00000
	30/5.6	200 ... 400 VDC	30 kW/5.6 kW	24 VDC	1 x 58 A/200 A	1 x 104 A/200 A	EMDAG4562303S00000
	30/2.8	400 ... 800 VDC	30 kW/2.8 kW	12 VDC	1 x 32 A/200 A	1 x 57 A/200 A	EMDAG4282303T00000
	30/2.8	200 ... 400 VDC	30 kW/2.8 kW	12 VDC	1 x 58 A/200 A	1 x 104 A/200 A	EMDAG4282303P00000
	15/5.6	400 ... 800 VDC	15 kW/5.6 kW	24 VDC	1 x 15 A/200 A	1 x 27 A/200 A	EMDAG4562153C00000
	15/5.6	200 ... 400 VDC	15 kW/5.6 kW	24 VDC	1 x 32 A/200 A	1 x 57 A/200 A	EMDAG4562153S00000
	15/2.8	400 ... 800 VDC	15 kW/2.8 kW	12 VDC	1 x 15 A/200 A	1 x 27 A/200 A	EMDAG4282153T00000
15/2.8	200 ... 400 VDC	15 kW/2.8 kW	12 VDC	1 x 32 A/200 A	1 x 57 A/200 A	EMDAG4282153P00000	
PSU	5,6	400 ... 800 VDC	5.6 kW	24 VDC	-/200 A	-/200 A	EMDAG3562000C00000
	5,6	200 ... 400 VDC	5.6 kW	24 VDC	-/200 A	-/200 A	EMDAG3562000S00000
	2,8	400 ... 800 VDC	2.8 kW	12 VDC	-/200 A	-/200 A	EMDAG3282000T00000
	2,8	200 ... 400 VDC	2.8 kW	12 VDC	-/200 A	-/200 A	EMDAG3282000P00000

Available with the impending Hardware Revision 010							
DCU	60/60	200 ... 848 VDC	2 x 60 kW	-	2 x 58 A	2 x 104 A	EMDAG2603603U00010
	30/30	200 ... 848 VDC	2 x 30 kW	-	2 x 32 A	2 x 57 A	EMDAG2303303U00010
	30/15	200 ... 848 VDC	1 x 30 kW 1 x 15 kW	-	1 x 32 A 1 x 15 A	1 x 57 A 1 x 27 A	EMDAG2303153U00010
	15/7.5	200 ... 848 VDC	1 x 15 kW 1 x 7.5 kW	-	1 x 15 A 1 x 8 A	1 x 27 A 1 x 14 A	EMDAG2153752U00010
DCU PSU	60/5.6	360 ... 848 VDC	60 kW/5.6 kW	24 VDC	1 x 58 A/200 A	1 x 104 A/200 A	EMDAG4562603C00010
	60/2.8	360 ... 848 VDC	60 kW/2.8 kW	12 VDC	1 x 58 A/200 A	1 x 104 A/200 A	EMDAG4282603T00010
	30/5.6	360 ... 848 VDC	30 kW/5.6 kW	24 VDC	1 x 32 A/200 A	1 x 57 A/200 A	EMDAG4562303C00010
	30/2.8	200 ... 848 VDC	30 kW/2.8 kW	12 VDC	1 x 32 A/200 A	1 x 57 A/200 A	EMDAG4282303T00010
	15/5.6	360 ... 848 VDC	15 kW/5.6 kW	24 VDC	1 x 15 A/200 A	1 x 27 A/200 A	EMDAG4562153C00010
	15/2.8	200 ... 848 VDC	15 kW/2.8 kW	12 VDC	1 x 15 A/200 A	1 x 27 A/200 A	EMDAG4282153T00010
PSU	5,6	360 ... 848 VDC	5.6 kW	24 VDC	-/200 A	-/200 A	EMDAG3562000C00010
	2,8	200 ... 848 VDC	2.8 kW	12 VDC	-/200 A	-/200 A	EMDAG3282000T00010

¹ inverter power at a DC-link voltage of 800 VDC/motor voltage of 560 VAC, DC/DC converter power with a DC output voltage 14/28 VDC

² peak current for 10 seconds

Accessories

Accessories	Type	Description	Type number
Power cable	X11	10 m, 4 x 2.5 mm ²	EMDY903A0100E41A00
Power cable	X12	10 m, 4 x 2.5 mm ²	EMDY903A0100E42A00
Power cable	X13 DCU	10 m, 4 x 2.5 mm ²	EMDY903A0100E43A00
Power cable	X13 PSU	10 m, 4 x 2.5 mm ²	EMDY903A0100E44A00
Power cable	X11	10 m, 4 x 4 mm ²	EMDY902A0100E31A00
Power cable	X12	10 m, 4 x 4 mm ²	EMDY902A0100E32A00
Power cable	X13 DCU	10 m, 4 x 4 mm ²	EMDY902A0100E33A00
Power cable	X13 PSU	10 m, 4 x 4 mm ²	EMDY902A0100E34A00
Power cable	X11	10 m, 4 x 6 mm ²	EMDY901A0100E21A00
Power cable	X12	10 m, 4 x 6 mm ²	EMDY901A0100E22A00
Power cable	X13 DCU	10 m, 4 x 6 mm ²	EMDY901A0100E23A00
Power cable	X13 PSU	10 m, 4 x 6 mm ²	EMDY901A0100E24A00
Power cable	X11	10 m, 4x10 mm ²	EMDY900A0100E11A00
Power cable	X12	10 m, 4 x 10 mm ²	EMDY900A0100E12A00
Power cable	X13 DCU	10 m, 4 x 10 mm ²	EMDY900A0100E13A00
Power cable	X13 PSU	10 m, 4 x 10 mm ²	EMDY900A0100E14A00
Sensor cable	X32/X33	1.5 m, SAC-8P-M12MR/1.5-PUR SH	EMDY700F0015B03A01
Sensor cable	X32/X33	3 m, SAC-8P-M12MR/3.0-PUR SH	EMDY700F0030B03A01
Sensor cable	X32/X33	5 m, SAC-8P-M12MR/5.0-PUR SH	EMDY700F0050B03A01
Sensor cable	X32/X33	10 m, SAC-8P-M12MR/10.0-PUR SH	EMDY700F0100B03A01
Power connector kit	X11/X12/X13	Including housing, crimp contacts, seals	EZAEVE027
Signal connector kit	X31	Including housing, crimp contacts, seals	EZAEVE028
Dummy plug	X11/X12/X13	Dummy plug for motor connection to DCU PSU or PSU	EZAMSK002
MOBILE Engineer	Single user licence	Supplied on USB dongle	EMDABUS01

X11: HV supply
X12: output inverter A
X13: output inverter B
X31: CAN interface
X32/X33: motor feedback

We are keen to help get your ideas moving forward! Learn more about our approach, our ways of thinking, our vision and how we can make things easier for you in future. Please feel free to contact us directly or visit us at:

**www.
Lenze-
Schmidhauser.
com**

This document is the intellectual property of Lenze SE, Hamelin (Germany). All details and information included in this brochure are correct based on the information available at the time of publishing and serve only to provide preliminary information. Potential colour deviations from the original product are due to the printing process. Lenze is the sole and exclusive owner of the copyright and the intellectual property rights. Any use of this document, in particular dissemination, reprinting or adapting, it is only permitted following express written approval by Lenze.

